

**THE 11th WORLD CONGRESS OF  
ASIAN PSYCHIATRY  
(WCAP2026)  
Sponsorship Prospectus**

Chair, Takahiro A. Kato

(Department of Psychiatry, Graduate School of Medicine, Hokkaido University)

## Table of Contents

Greetings ... 1

General Information ... 2

Budget ... 3

Donation Application Guidelines ... 4

Co-Sponsored Seminar Guidelines ... 5

Advertisement Application Guidelines ... 7

Exhibition Application Guidelines (Corporate and Book Exhibits) ... 9

## Greetings

It is with great pleasure that we extend our warmest greetings and best wishes for your continued health and prosperity.

On behalf of the Asian Federation of Psychiatric Associations (AFPA), it is my profound honor and privilege to invite you to the 11th World Congress of Asian Psychiatry (WCAP 2026), which will take place in the stunning city of Sapporo, Japan, from October 6 to 8, 2026.

The theme of the 11th WCAP Congress, **“Harmonization between Urbanization and Nature in Future Mental Health,”** highlights the vital need to balance the rapid pace of urbanization with the restorative power of nature in addressing mental health challenges. This theme reflects our shared commitment to exploring innovative solutions to the evolving complexities of mental health, including the impact of urban living, technological advancements, and environmental changes on psychological well-being.

Sapporo, the central city of Hokkaido, Japan, celebrated for its seamless fusion of natural beauty and urban sophistication, offers an ideal backdrop for this congress. Nestled amidst breathtaking landscapes and vibrant cityscapes, Sapporo embodies the spirit of harmony that lies at the heart of our theme. We anticipate the participation of numerous mental health experts and researchers from Japan and around the world.

While the Congress is primarily operated through participants' registration fees, current funding is insufficient to implement the high-quality program and initiatives outlined above.

Therefore, we sincerely ask for your endorsement of the spirit of WCAP 2026 and request your generous sponsorship. We are confident that your contribution will significantly enhance your visibility among the world's top-tier researchers and practitioners in the field of psychiatry.

Please do not hesitate to contact us should you have any questions or require further details regarding the sponsorship opportunities.

We sincerely request your support for the success of this important academic endeavor.

November 2025

The 11th World Congress of Asian Psychiatry (WCAP2026)

Chair, **Takahiro A. Kato**

## General Information

**1. Name of Congress:**

THE 11th WORLD CONGRESS OF ASIAN PSYCHIATRY (WCAP2026)

**2. Theme:**

Harmonization between Urbanization and Nature in Future Mental Health

**3. Chair:**

Takahiro A. Kato

(Department of Psychiatry, Graduate School of Medicine, Hokkaido University)

**4. Date:**

October 6 (Tue) – 8 (Thu), 2026

**5. Venue:**

Clark Memorial Hall, Hokkaido University

(Kita 8 Nishi 7, Kita-ku, Sapporo, Hokkaido 060-0808, Japan)

and other related venues

**6. Congress Summary**

1) Program Outline: Special Lectures, Educational Lectures, Symposia, Workshops,  
Oral/Poster Presentations, Co-sponsored Seminars, etc. (Tentative)

2) Participants: Approx. 500 (Tentative)

**7. Contact**

WCAP2026 Congress Secretariat

Convention Linkage, Inc., Hokkaido Office

Address: Sapporo Clock Tower Bldg. Kita 1 Nishi 2, Chuo-ku, Sapporo,

Hokkaido 060-0001, Japan

E-mail: wcap2026@c-linkage.co.jp

## Budget

### <Income Section>

(Unit: yen)

Items	Qty	Unit Price	Amount	Notes
<b>1 Registration Fees</b>	<b>500</b>		<b>21,300,000</b>	
Category A				
Early Registration	150	45,000	6,750,000	
Standard Registration	110	50,000	5,500,000	
On-site Registration	20	55,000	1,100,000	
Category B				
Early Registration	60	40,000	2,400,000	
Standard Registration	60	45,000	2,700,000	
On-site Registration	0	50,000	0	
Category C				
Early Registration	20	35,000	700,000	
Standard Registration	20	40,000	800,000	
On-site Registration	0	45,000	0	
Category D				
Early Registration	10	30,000	300,000	
Standard Registration	10	35,000	350,000	
On-site Registration	0	40,000	0	
Students, Residents & Accompanying Persons				
Early Registration	20	15,000	300,000	
Standard Registration	20	20,000	400,000	
On-site Registration	0	25,000	0	
<b>2 Farewell Dinner</b>	<b>60</b>		<b>480,000</b>	
Advance Registration	50	8,000	400,000	
On-site Registration	10	8,000	80,000	
<b>3 Co-sponsored Seminar Fees</b>			<b>6,600,000</b>	
Sponsorship	4	1,650,000	6,600,000	
<b>4 Exhibition Fees</b>			<b>1,683,000</b>	
Corporate Exhibition	6	275,000	1,650,000	
Book Display	2	16,500	33,000	
<b>5 Advertisement Fees</b>			<b>2,365,000</b>	
Abstract Book: Inside Front Cover	1	275,000	275,000	
Abstract Book: Back Cover	1	220,000	220,000	
Abstract Book: Inside Back Cover	1	220,000	220,000	
Abstract Book: Postscript Page 1	5	110,000	550,000	
Abstract Book: Postscript Half-Page	10	77,000	770,000	
Website Banner Ad	3	110,000	330,000	
<b>6 Grants, Subsidies &amp; Donations</b>			<b>1,000,000</b>	
Corporate/Organizational Donations			1,000,000	
<b>Total Income</b>			<b>33,428,000</b>	

### <Expenditure Section>

(Unit: yen)

Items	Total	Notes
<b>1 Pre-Congress Preparation Costs</b>	<b>13,080,000</b>	
(1) Secretariat Expenses	4,580,000	
(2) Website Development	1,500,000	
(3) Abstract & Advance Registration Related Costs	3,000,000	
(4) Publicity & Promotion Costs	1,000,000	
(5) Other Production/Miscellaneous Costs	3,000,000	
<b>2 On-site Operation Costs</b>	<b>16,348,000</b>	
(1) Venue Rental Fee	1,008,480	
(2) Equipment & Supplies Related Costs	4,000,000	
(3) On-site Operation & Personnel Costs	2,800,000	
(4) Signage & Directional Guide Costs	2,800,000	
(5) Food & Beverage Related Costs	2,939,520	
(6) Conference Supplies & Miscellaneous	1,400,000	
(7) Invitation & Speaker Fees	1,400,000	
<b>3 Social Event Expenses</b>	<b>3,500,000</b>	
<b>4 Post-Congress Processing Costs</b>	<b>500,000</b>	
<b>Total Expenditure</b>	<b>33,428,000</b>	

# Donation Application Guidelines

## 1. Name of Donation

THE 11th WORLD CONGRESS OF ASIAN PSYCHIATRY (WCAP 2026) Donation

## 2. Application Period

Until Thursday, October 8, 2026

## 3. Target Donation Amount

JPY 1,000,000

## 4. Target Donors

General Corporations, Private Foundations, Medical Institutions, etc.

## 5. Purpose of Donations

The money will be used for the preparation, operation, and related event costs for the Congress.

## 6. Application Method

Please access the application form below and fill it out.

<https://forms.gle/DkxxVfFWNd8ieG6EA>

## 7. Bank Transfer Details for Donation

Please transfer the amount to the designated bank account after submitting your application.

Bank Name: North Pacific Bank, Ltd. (0501)

Branch Name: Kita Seven-Jo Branch (312)

SWIFT/BIC Code: NORPJPJP

Account Type: Savings Account

Account Number: 7236730

Account Name: WCAP2026

## Note

※The bank transfer fee must be borne by the donor (your company).

※The bank's deposit slip will be used as the receipt from our organization.

※This donation is not eligible for tax deductions.

## Co-Sponsored Seminar Guidelines

### I. General Information (Date & Time, Co-sponsorship Fee, and Details)

<Luncheon Seminar>

Application Number	Date & Time		Venue (Tentative)	Seating Capacity (Tentative)	Co-sponsorship Fee (incl. tax)
LS-A-1	Oct. 7 (Wed)	12:20-13:20	Assembly Hall 1	90 seats	JPY 1,650,000
LS-A-2		12:20-13:20	Assembly Hall 2	90 seats	JPY 1,650,000
LS-B-1	Oct. 8 (Thu)	12:20-13:20	Assembly Hall 1	90 seats	JPY 1,650,000
LS-B-2		12:20-13:20	Assembly Hall 2	90 seats	JPY 1,650,000

※Included in the Fee: Venue rental, venue amenities (e.g., tables, chairs, stage, audio-visual equipment, lighting), and lecture equipment (e.g., projector, screen, and other presentation equipment arranged by the Congress).

※Seating: All seating will be arranged in a theatre style.

The capacity listed is an estimate; the actual number of seats may be reduced by 10-20%.

※Venue Changes: Please note that the venue may need to change due to scheduling or program needs. We appreciate your understanding.

### 2. Venue and Schedule Determination

The organizers will decide the venue and schedule after the application deadline, based on the lecture theme, speaker profiles, and content. Please do not formally invite or commit to potential speakers before the final decision is officially confirmed.

The number of venues is limited, and we may not be able to accept all requests. We ask for your understanding in advance.

### 3. Notes on Additional Expenses

The following costs are not included in the Co-sponsorship Fee and must be paid by the co-sponsoring company:

#### 1) Chair and Speaker Expenses:

- Honoraria, travel, and accommodation costs.

#### 2) Meal Expenses:

- Meals for participants (including beverages/lunchboxes).

- Meals for the Chair and Speakers during preparatory meetings, etc.

※**Strict note:** Bringing outside food and beverages is strictly prohibited due to venue rules.

### 3) Personnel Expenses (Staffing):

- Wages for seminar operation staff (e.g., announcers, staff for distributing lunchboxes/materials, lighting operators, directional guides, etc.).

### 4) Signage and Display Materials:

- Printing and production costs for venue signs (standing sign: 600x900mm), name displays for the Chair/Speakers (300x600mm), posters, and seminar invitations (A4 flyers), etc.

※**Strict note:** The standing sign and name displays must use the Congress's unified design, so bringing outside signage for these items is strictly prohibited.

### 5) Additional Equipment:

- Equipment for simultaneous interpretation, recording, or equipment for the preparation/waiting room, etc.

※**Business Management Fee:** For items 2) through 5) above, a Business Management Fee of 15% of the total cost will be charged as a handling fee.

## 4. Application Method

Please access the application form below and fill it out.

<https://forms.gle/DkxxVfFWNd8ieG6EA>

## 5. Application Deadline

**Deadline: Wednesday, May 13, 2026**

- ※ As the number of available venues is limited, applications will be closed once the maximum number of seminars is reached.
- ※ Joint hosting with multiple companies is also possible.

# Advertisement Application Guidelines

## 1. Program and Abstract Book Advertisement

**Format:** A4 size, Perfect Binding (Left-hand bind)

**Publication Date:** October 2026

**Circulation:** 600 copies (Tentative)

**Production Cost:** JPY 2,035,000 円(Tentative)

**Advertisement fee**

Placement		Color Specification	Number of Slots	Fee (Tax Included)
Abstract Book	Back Cover (Outside)	Color	1	JPY 275,000
	Back Cover (Inside)	Black & White	1	JPY 220,000
	Front Cover (Inside)	Black & White	1	JPY 220,000
	Postscript Page (Full Page)	Black & White	5	JPY 110,000
	Postscript Page (Half Page)	Black & White	10	JPY 77,000

※The organizer has the right to decide all page allocations.

※Artwork Submission: Please submit your artwork as an EPS data file (Illustrator and Photoshop files are also accepted).

- Size: A4 portrait (vertical) for full page; A5 landscape (horizontal) for half page.

- Text: All text must be converted to outlines to prevent font issues.

- Sending Data: Send the data via E-mail to the address listed in the "Data Submission Contact" section.

## 2. Website Banner Advertisement

**Specifications:** 100px (H) x 320px (W) (Negotiable), JPEG or GIF format (Animation not allowed)

**Posting Period:** After submission of the artwork until March 2027 (Tentative)

**Posting Fee:** JPY 110,000 (Tax Included) / per slot

**Number of Slots:** 3 slots

※The placement of the banner advertisement on the website is at the sole discretion of the Congress organizers.

## 3. Application Method

Please access the application form below and fill it out.

<https://forms.gle/DkxxVfFWNd8ieG6EA>

## 4. Application and Submission Deadline

**Deadline: Wednesday, May 13, 2026**

- ※The deadline for submission of the final artwork is the same date.
- ※Please note that the number of slots for each item is limited. Applications will be closed once the planned number of slots is reached, even if it is before the deadline. We encourage you to apply early.
- ※The Congress reserves the right to decline any advertisement if its content is deemed unsuitable or inconsistent with the aims and objectives of the Congress.

## 5. Data Submission Contact

The 11th World Congress of Asian Psychiatry Secretariat  
E-mail: [wcap2026@c-linkage.co.jp](mailto:wcap2026@c-linkage.co.jp)

## 6. Others

- If there are too many applications for a specific page or medium, the Organizing Committee will carefully review all submissions.
- The organizers will make the final decision, and the result will be sent to each applicant by the Congress Secretariat.
- Advertisers who place an advertisement in the Program and Abstract Book will receive a free copy of the book.

# Exhibition Application Guidelines (Corporate and Book Exhibits)

## 1. Tentative Exhibition Schedule

**Move-in / Setup:** Monday, October 5, 2026 (Afternoon)  
**Exhibition Open:** Tuesday, October 6, 2026, 9:30-17:30  
 Wednesday, October 7, 2026, 9:30-17:30  
 Thursday, October 8, 2026, 9:30-16:00  
**Move-out / Dismantling:** Thursday, October 8, 2026, 16:00-18:00

## 2. Venue

Clark Memorial Student Center, Hokkaido University  
 (Kita 8, Nishi 7, Kita-ku, Sapporo, Hokkaido 060-0808, Japan)

## 3. Exhibition Types and Fees

Type	Specifications	Exhibition Fee (incl. tax)	Number of Booths Available
Corporate Exhibit Booth	<ul style="list-style-type: none"> <li>Booth size: W1800mm×H2100mm×D450mm</li> <li>Located within a conference room (each exhibitor will be assigned a section of the room, where the booth will be set up).</li> </ul>	JPY 275,000 /Booth	6 companies
Book Exhibit Booth	<ul style="list-style-type: none"> <li>Table size: W1800mm×D450mm</li> <li>Table only (one table per booth).</li> </ul>	JPY 16,500 /Booth	2 booths

« Image of Corporate Exhibit Booth »

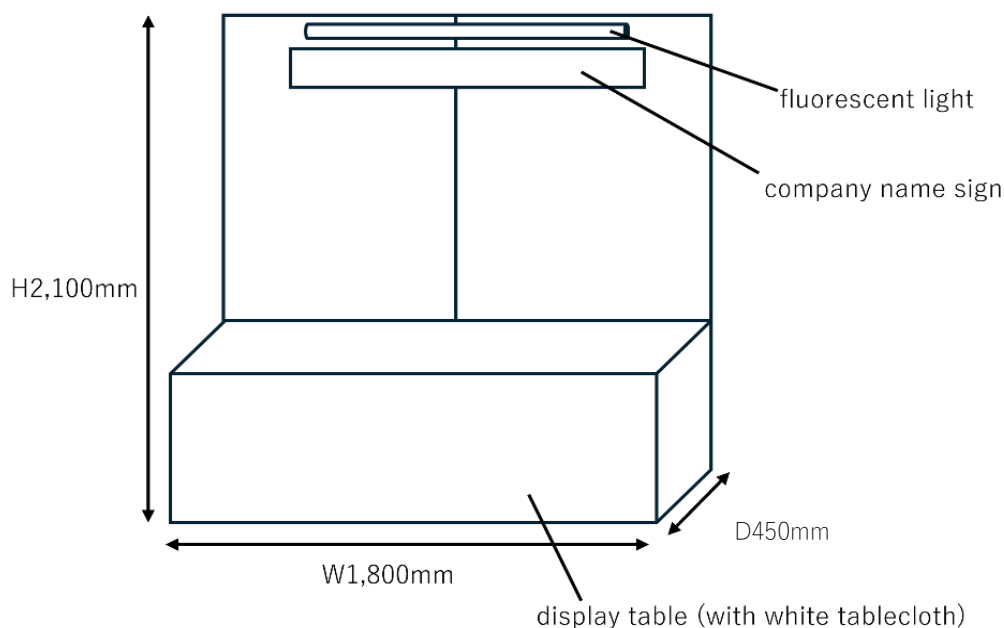

« Image of Book Exhibit Booth»

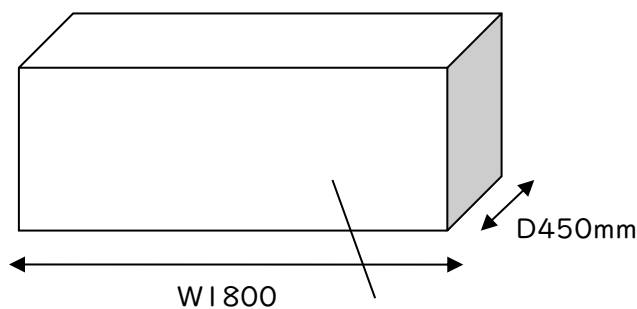

Book Exhibit Table

(Tablecloth is not included; please bring your own.)

\* The size of Book Exhibit table is subject to change. The detailed will be announced until the end of June, 2026.

#### 4. Application Method

Please access the application form below and fill it out.

<https://forms.gle/DkxxVfFWNd8ieG6EA>

#### 5. Application Deadline

**Wednesday, May 13, 2026**

※Please note that if the maximum number of booths is reached, applications may be closed before this date. We encourage you to apply early.

#### 6. Payment Method for Exhibition Fee

Please transfer the total booth fee to the bank account indicated on the invoice within one month of the invoice issuance date.

Please note that if payment is not received by the start of the exhibition, your booth reservation will be canceled.

#### 7. Cancellation of Exhibition

Once the application form has been submitted, withdrawal is not permitted, except in cases recognized by the organizers as force majeure.

#### 8. Booth Assignment

Booths will be assigned by the organizers after the application deadline, considering the type of exhibits, number/configuration of booths, and whether demonstrations are conducted. The operations office will notify each exhibitor. Exhibitors cannot object to their booth assignment. Booths may not be transferred or exchanged without prior approval from the organizers.

※Exhibitors are responsible for their own exhibits. The organizers assume no liability for theft, loss, or damage.

## Designated Bank Transfer Account

After your application is submitted and approved by the organizer, an invoice will be issued and sent to you. Please remit the relevant sponsorship fees to the designated bank account indicated on the invoice within one month from the invoice date.

Bank transfer fees shall be borne by the applicant.

The payment slip/receipt issued by the financial institution will serve as the official receipt.

## Disclosure of Information

Pursuant to *the Transparency Guidelines for the Relationship between Corporate Activities and Medical Institutions*, etc. promulgated by *the Japan Pharmaceutical Manufacturers Association* and *the Japan Generic Medicines Association*, as well as *the Transparency Guidelines for the Relationship between the Medical Device Industry and Medical Institutions*, etc. issued by *the Japan Federation of Medical Devices Associations*, and in accordance with *the Guidelines on Transparency in the Relationship between Corporate Activities and Medical Institutions/Healthcare Professionals*, we hereby acknowledge and consent that any sponsorship fees or related financial contributions remitted by your company to this Academic Society shall be subject to disclosure via your company's website or any other publicly accessible medium deemed appropriate by your company.

## Contact Information

WCAP 2026 Congress Secretariat

c/o Convention Linkage, Inc.

Sapporo Tokeidai Bldg., 2-1 Kita 1-Jo Nishi, Chuo-ku,

Sapporo, Hokkaido, 060-0001, Japan.

E-mail: [wcap2026@c-linkage.co.jp](mailto:wcap2026@c-linkage.co.jp)